

RCA Theremin

SERVICE NOTES

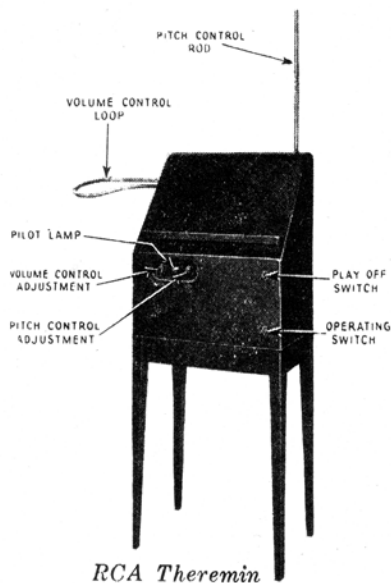

RCA Theremin

[First Edition—5M
Copyright November 1929]

RADIO-VICTOR CORPORATION OF AMERICA

233 BROADWAY, NEW YORK CITY

DISTRICT SERVICE STATIONS

BROOKLYN, N. Y.
Bldg. No. 19—168 - 39th St.

CHICAGO, ILL.
2001 West Pershing Road

DALLAS, TEXAS
Santa Fe Bldg., Unit No. 2

SAN FRANCISCO, CAL.
274 Brannan St.

ATLANTA, GA.
150 Peters St.

PREFACE

The RCA Theremin is an electrical musical instrument played by the free movement of the hands in space. The actual production of sound is accomplished by means of a loudspeaker which must be connected to the RCA Theremin. The loudspeaker may be located close to the Theremin or at any convenient distance as required.

The electrical circuits incorporated in the instrument are designed to operate from the house lighting circuit controlled by a power switch mounted on the cabinet. Provision is also made for adjusting pitch and volume by suitable panel controls. A "play-off" switch provides for turning "On or Off" the Theremin with switching off the power supply.

A knowledge of the design and operation of the instrument is desirable if any service work becomes necessary. The present RCA Service Notes have been prepared to provide service personnel with practical helps and technical information in the performance of this service work. This information has been compiled from experience with the problems encountered and presents the best practice in dealing with them. A careful reading of these Service Notes will establish their value and it is suggested they be preserved for ready reference.

In addition to supplying the Service Notes RCA maintains a corps of engineers who visit the trade at frequent intervals to advise and assist in the performance of Service Work.

Property of the Radio-victor Corporation of America. Confidential and to be used only by those authorized by RCA to furnish service in connection with its apparatus.

Copyright 1929—Radio-victor Corporation of America

CONTENTS

	Page
Preface	2
Electrical and Physical Specifications.....	5
Introduction	5
Electrical Description of Circuits.....	5

PART I—SERVICE DATA

Installation	8	Skip Effect in Pitch Control.....	10
Normal Operation	8	Service Data Chart	11
Volume Control Adjustments.....	9	S. P. U. Terminal Strip Voltages.....	13
Pitch Adjustment Condenser Not at Center....	10	Theremin Radiotron Socket Voltages.....	13
Range Below 1100 Cycles.....	10	Methods for Continuity Tests.....	15
Reversed Action of Pitch Control.....	10	S. P. U. Continuity Tests.....	15
High Pitched Note.....	10	Main Assembly Continuity Test.....	17

PART II—MAKING REPLACEMENTS

Replacing Parts in the Theremin Assembly....	18	Removal of Parts and Location of Cable.....	18
--	----	---	----

ILLUSTRATIONS

RCA Theremin	1	Schematic Circuit Diagram of the Socket Power Unit	9
Rear Interior Cabinet View.....	4	Complete Layout and Cable Connections.....	12
Top Chassis View of the Main Assembly.....	6	Wiring Diagram of the Socket Power Unit....	14
Sub-chassis View of the Main Assembly.....	7	Wiring Diagram of the Main Assembly.....	16
Schematic Circuit Diagram of the Main Assembly	8	Internal Connections of Filter and By-Pass Condensers, and Filter Reactor.....	18

RCA THEREMIN

SERVICE NOTES

Prepared by RCA Service Department

PITCH RESONANCE CONTROL COIL THEREMIN ASSEMBLY VOLUME RESONANCE CONTROL COIL

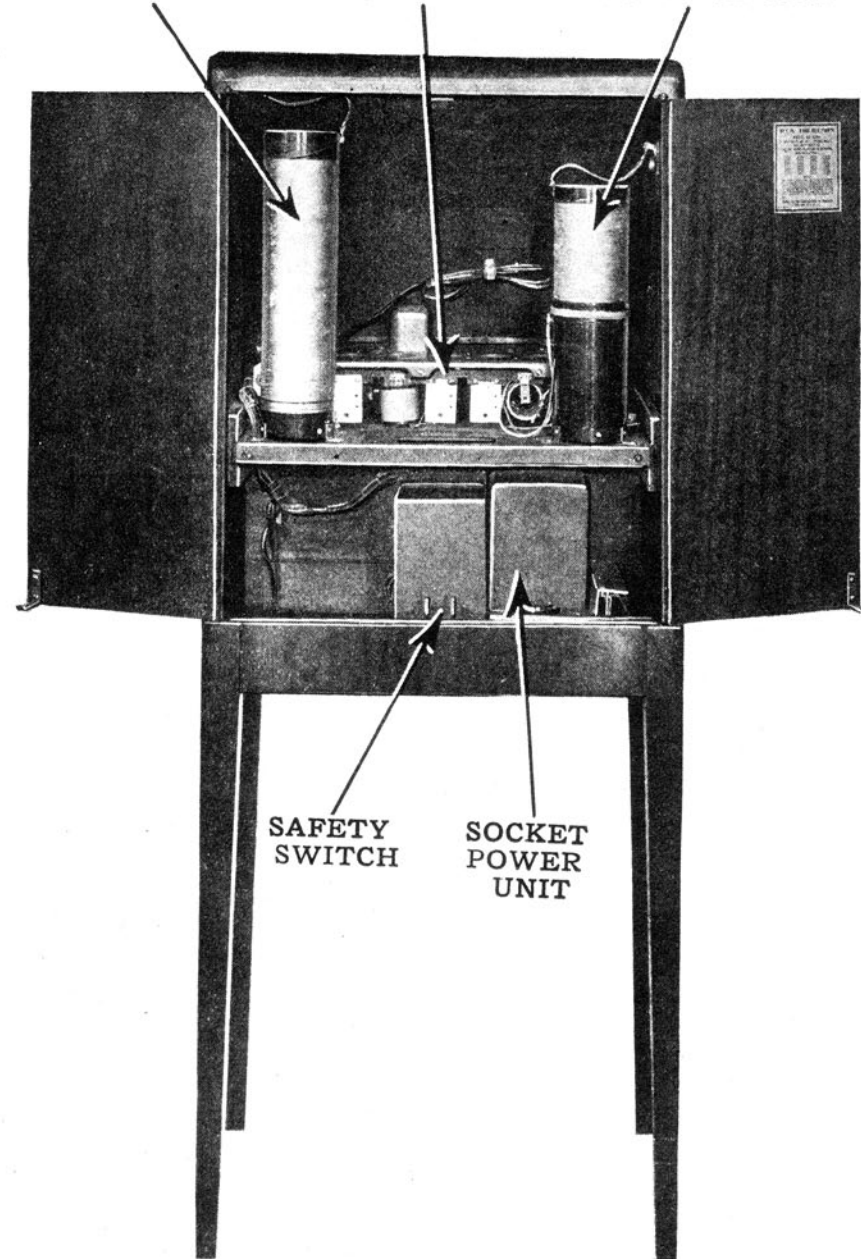

Figure 1—Rear interior cabinet view

ELECTRICAL SPECIFICATIONS

Voltage Rating	105-125 Volts
Frequency Rating	50-60 Cycles
Power Consumption	90 Watts
Type of Circuit	Special beat frequency oscillator with audio stages
Number and Types of Tubes	Three UY-227, 1 UY-224, 1 UX-120, 2 UX-171A, and 1 UX-280—Total 8
Number of Oscillators	3
Type of Detector	Two-grid detector modulator
Number of A. F. Stages	2
Recommended Loudspeaker	RCA Loudspeaker 106
Musical Range— $3\frac{1}{2}$ Octaves	Lowest note of loudspeaker to 1400 cycles approximately

PHYSICAL SPECIFICATIONS

Height to top of Pitch Control Rod	64 in.
Height of Cabinet	46½ in.
Width, including Volume Control Loop	31½ in.
Width of Cabinet	19 in.
Depth	12 in.
Dimensions of Packing Case	14½ in. x 24 in. x 51 in.
Weight, Net	67½ lbs.
Weight, Shipping	99 lbs.

INTRODUCTION

The RCA Theremin is a musical instrument operating entirely on electrical principles and played by the movement of the hands in space. Having no limitations such as key boards, stops, etc., exceptional individuality of expression may be obtained. The instrument covers approximately three and one half octaves, the highest note being about 1400 cycles. Figure 1 illustrates a rear interior cabinet view and Figures 2 and 3 a top and bottom chassis view of the main assembly. The operation of this instrument is covered in the instruction book accompanying each RCA Theremin.

The principle of operation of the RCA Theremin is that of the beat frequency oscillator. The frequency of one oscillator may be varied by the capacity change caused in an associated circuit by the movement of the hand to or from a pitch control rod. Also an additional oscillator provides radio frequency current for heating the filament of a UX-120 arranged so as to control the volume of output, this control being due to the movement of the hand in relation to the volume control loop. A detailed description of the functioning of the various circuits follows:

ELECTRICAL DESCRIPTION OF CIRCUITS

As stated in the foregoing, the musical note of the RCA Theremin is produced by two oscillators of slightly different frequency beating together. This beat note is then amplified by two audio stages. The change of note caused by the movement of the hand is due to the change of capacity across what is known as the pitch coil, this slight change having sufficient effect on an adjacent oscillator circuit to change the frequency and thus the beat note, the amount of change depending on the position of the hand in relation to the pitch control rod.

Scanned and updated by Mike Buffington. RCATheremin.com

Scanned and updated by Mike Buffington. RCATheremin.com

Referring to the schematic circuit Figures 4 and 5 and starting from the pitch control rod we find the circuits functioning as follows:—

The pitch control rod is connected to a coil having a very high inductance. Connected to this coil is a small condenser and a small concentrated coil. This entire circuit is tuned by the distributed capacity of its coils and resonates at approximately 172 K.C. Not having any fixed capacitor connected across it for tuning, the ratio of inductance to capacitance is very high. Thus the small increase of capacity caused by the hand close to the pitch rod will cause the circuit to change its natural period considerably, a great deal more than if a large capacity and small inductance were used.

This pitch control circuit is connected to the grid side of the variable pitch control oscillator the frequency of which is slightly greater than that of the pitch control circuit. Bringing the hand close to the pitch rod will increase the parallel capacity in that circuit and thus reduce its frequency. As this capacity is reflected in the oscillator circuit a similar decrease in frequency will result in that circuit, the amount of decrease depending on the closeness of the frequency of the two circuits. Thus a greater decrease in frequency of the oscillator circuit is obtained when the pitch control circuit is close to the oscillator circuit in frequency than when it is at a greater frequency difference.

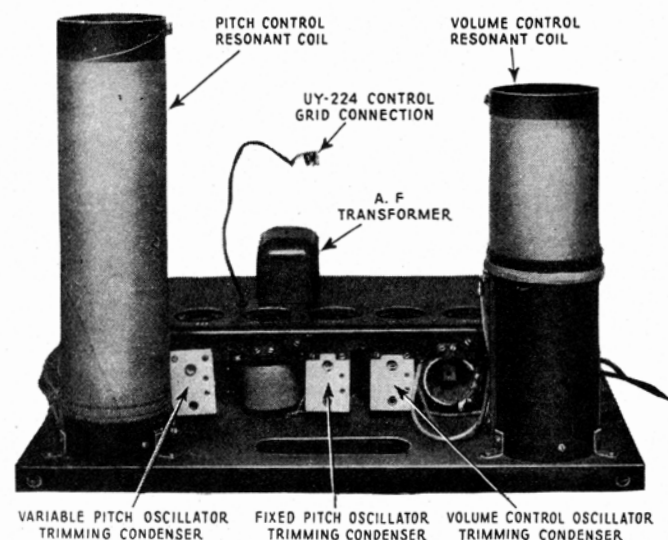

Figure 2—Top chassis view of the main assembly

The next circuit to examine is the fixed pitch oscillator. This circuit oscillates at a frequency, when correctly adjusted, at a maximum of 1400 cycles greater than the variable pitch oscillator. The amount of this difference is dependent on the frequency of the variable pitch oscillator the frequency of which is determined by the position of the hand in relation to the pitch control rod. The frequency of the fixed pitch oscillator does not change while playing.

An example of the functioning of these three circuits follows:—

The hand approaches the pitch control rod and increases the capacity across the pitch control circuit. This capacity is reflected across the variable pitch control oscillator and thus reduces its frequency. This causes an audible frequency difference between this oscillator and the fixed pitch oscillator, the frequency of this note depending on the position of the hand. Bringing the hand close to the rod will increase the capacity in the pitch control circuit, reduce the frequency of the variable pitch oscillator and increase the difference between the frequency of this oscillator and the fixed pitch oscillator. Thus an audible note is obtained, the note increasing in frequency as the hand approaches the pitch control rod.

Examining the circuit diagram we find that each oscillator grid is connected to the control and screen grid respectively of a Radiotron UY-224. As the screen grid has the largest area, a 10,000-ohm resistance is connected in series with it to balance the input to this tube and have each oscillator have the same effect on the detector action. This tube is a detector or combining tube that functions much in the same

manner as the first detector in a super-heterodyne circuit. The output of the detector is then amplified by a two-stage audio frequency amplifier, the output of which goes to the loudspeaker.

The remaining two tubes, Radiotron UX-120 and UX-171A together with the first audio frequency amplifier constitute the volume control system. Examining the UX-171A we find that it is in an oscillating circuit that oscillates at about 420 K.C. Connected to the grid side of the oscillator is the volume control loop circuit. This circuit resonates at a frequency below the oscillator frequency when the hand is entirely removed from the volume control loop. This is done for two reasons. If the two circuits were in exact resonance, the load on the oscillator would be too great and operation would be unstable. Also the pick-up current would be high and might damage the tube. The ratio of inductance to capacity in this circuit is also quite high. A small pick-up coil is wound around the inductance coil of the volume control loop circuit and when both circuits are nearly in resonance (hand entirely removed) sufficient radio frequency current flows in this pick-up coil to light the filament of the Radiotron UX-120 to which it is connected. If the plate supply circuit to the Radiotron UY-227, that is the first audio frequency amplifier, is examined we see that the current for this tube is fed through the UX-120. Thus if the UX-120 were at maximum brilliancy, maximum

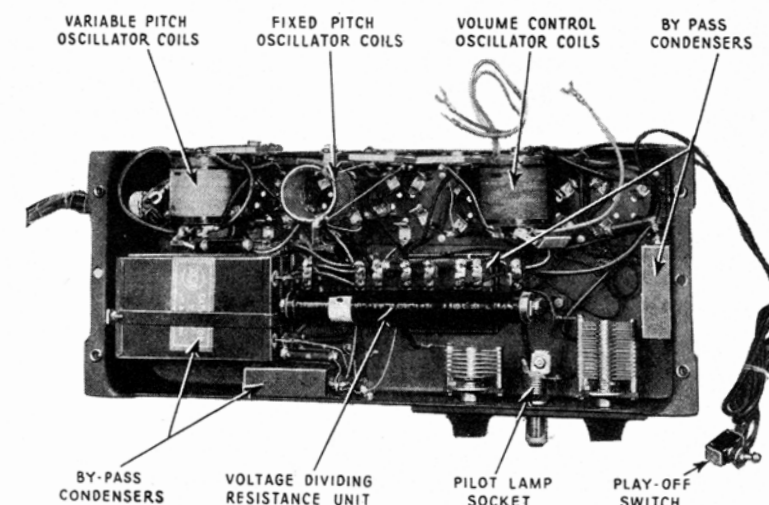

Figure 3—Sub-chassis view of the main assembly

volume would be obtained. Likewise if it were not lighted no signal output would be obtained due to no plate current flowing.

A condenser and resistor are placed in the plate voltage supply to the first audio tube which regulates the time constant of the volume control. They are adjusted to prevent any undue lag in operation of the volume control, while preventing quick accidental variations in volume due to a slight unsteadiness of the hand. The condenser also increases the efficiency of the audio amplifier by preventing a loss of A.C. voltage across the Radiotron UX-120. The low side of the resistance instead of being connected to ground is connected to a tap on the grid leak of the volume control oscillator. This supplies a small negative potential to the plate of the first audio tube and insures that zero volume is secured when the UX-120 emission is zero or nearly so.

Now getting back to the oscillator circuit that lights the filament of the UX-120 we see that if the load current is reduced, the brilliancy of the UX-120 will be decreased and likewise the volume. Thus when the hand approaches the volume control loop, the natural period of the circuit is decreased in frequency, the circuit is out of resonance with the oscillator by an amount depending on the position of the hand and less current is flowing in the pick-up coil with a consequent reduction in volume.

Thus we see from the foregoing explanation, a movement of one hand in relation to the pitch control rod will cause a variation in pitch and thus allow the playing of music. A movement of the other hand in relation to the volume control loop will cause an increase or decrease in volume. The combination of these two movements constitutes the technique of playing the RCA Theremin.

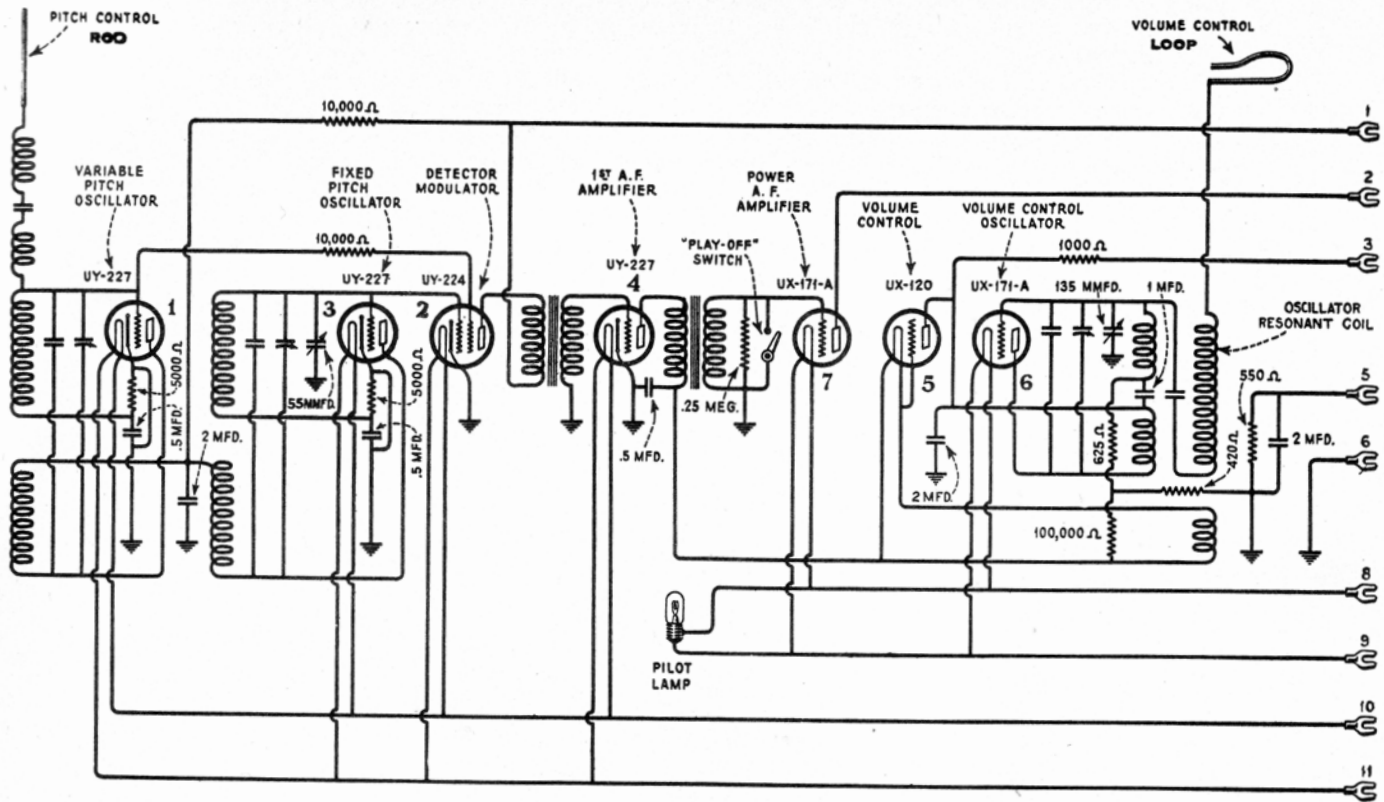

Figure 4—Schematic circuit diagram of the main assembly

PART I—SERVICE DATA

(1) INSTALLATION

The necessary instructions for installing the RCA Theremin are contained in the instruction book that accompanies each instrument. The notes on location with regard to metal objects and all other points should be carefully checked, as satisfactory operation depends on correct installation.

(2) NORMAL OPERATION

Normal operation of the RCA Theremin may be checked in the following manner:—

- Place the Theremin in operation by turning "On" the operating switch, turning the "Play-Off" switch to "Play" and making sure the rear doors are closed.
- Stand erect directly in front of the Theremin so that the body is at a distance from the cabinet determined by placing the right arm straight out from the shoulder with the hand closed. In this position the hand should just reach the pitch control rod.
- Now pull the right arm back to the shoulder. The Theremin should just approach zero beat in this position when the pitch adjustment condenser is at its mid-position. If zero beat is not obtained adjust the pitch adjustment until it is obtained with the hand in this position. Now extend the hand until it is one inch from the pitch antenna. At this point a note of from 1100 to 1400 cycles should be obtained. This may be checked with a piano. C sharp, two octaves above middle C is 1096 cycles and F sharp, two octaves above middle C is 1463 cycles. If these conditions are not fulfilled or the pitch adjustment condenser is not in the center, adjust as described in Part I, Section 4.

The volume control may be checked as follows:—

- With the Theremin in operation and an audible note obtained, a good loud signal should be obtained with the hand entirely removed from the volume

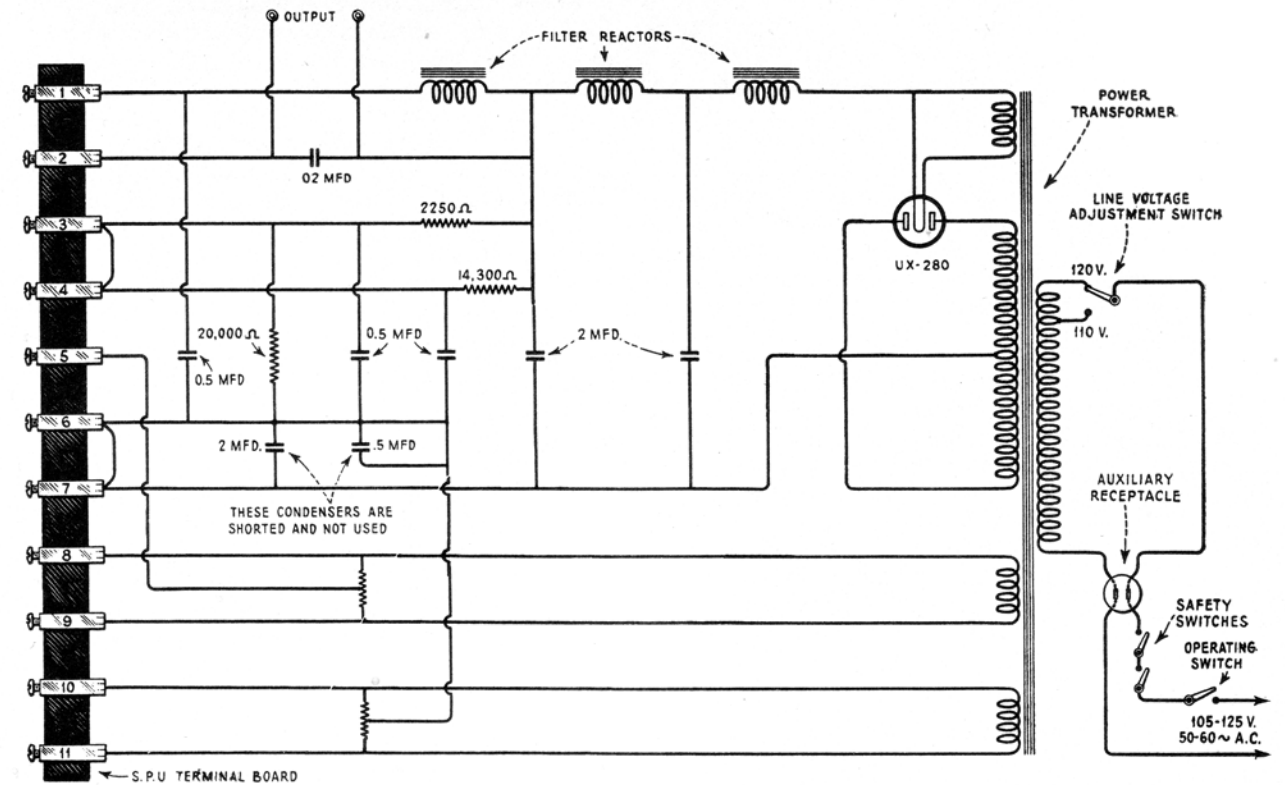

Figure 5—Schematic circuit diagram of the socket power unit

control loop and the volume control adjustment at maximum (To the right). Placing the hand close to the volume control loop should reduce the volume and give complete cut-off when the hand is three inches above the loop and the volume control adjustment is at maximum. If cut-off is not obtained until the hand is closer or at a greater distance, an adjustment such as described in Part I, Section 3, must be made.

(3) VOLUME CONTROL ADJUSTMENTS

Should normal operation of the volume control not be obtained proceed as follows:—

- Volume control cuts off when the hand is at a greater distance than three inches from the loop, the volume adjustment condenser being to the extreme right or maximum position. Also full volume is not obtained when the hand is completely removed. The remedy in this case is to increase the capacity of the volume control oscillator trimming condenser. This condenser is the extreme right one when looking at the Theremin from the rear with the doors open.
- Volume control cuts off when the hand is less than three inches from the loop, the volume adjustment condenser being at maximum. The remedy in this case is to reduce the capacity at the volume control trimming condenser on the rear of the chassis until a normal condition is obtained.
- Volume control has reversed action or goes from low volume to high and then low while the hand approaches the loop. This is due to being on the wrong side of the resonance curve or in the latter condition going from one side of resonance through resonance and then to the other side. The remedy in both cases is to reduce the capacity at the volume control oscillator trimming condenser until normal operation is secured.
- A more accurate method of adjusting the volume control is by the use of a milliammeter. An adapter is necessary, which may be either a UY or UX type and having means for breaking the plate circuit. This adapter may be

placed either in the UX-120 socket in the case of the four-prong UX type or in the first audio UY-227 socket. A 0-5 milliammeter is placed in series with the plate of either tube through the connections provided in the adapter.

The volume adjustment on the front of the Theremin is then set at maximum. The right rear door is now opened, the safety switch held down with one hand and the volume control oscillator trimming condenser adjusted until the milliammeter indicates 2 M.A. is flowing with door closed. The pitch should be around zero beat when making this adjustment. This is the correct adjustment provided the effect noted in (c) is not obtained, in which case the capacity should be reduced until another reading of 2 M.A. is obtained. Thus the correct adjustment is found when the milliammeter reads 2 with the least capacity at which such a reading may be obtained.

(4) PITCH ADJUSTMENT CONDENSER NOT AT CENTER

If the conditions indicated in Part I, Section 2 are fulfilled but with the pitch adjustment condenser off center, it may be corrected as follows:—

- (a) If the pitch adjustment is too far to the right, indicating too much capacity, the remedy is to increase the capacity of the fixed pitch oscillator trimming condenser located on the rear of the chassis. This is the center of the trimming condensers.
- (b) If the pitch adjustment is too far to the left, indicating too little capacity, reduce the capacity of the fixed pitch oscillator trimming condenser.

Both of these adjustments must be made by changing the trimming condenser a little at a time, closing the rear doors and checking from the front for normal operation.

(5) RANGE BELOW 1100 CYCLES

This indicates the fixed pitch oscillator and variable pitch oscillator are at too great a frequency difference from the pitch control circuit. The remedy is to increase both the fixed pitch oscillator and the variable pitch oscillator trimming condensers until the necessary high note is obtained. These are the left and center trimming condensers respectively at the rear of the Theremin. Care should be taken not to adjust the oscillators so that the note will be higher than 1400 cycles, as unstable operation may result. 1100 cycles is about C sharp, two octaves above middle C, and 1400 cycles about F sharp, two octaves above middle C on a piano. A tuning fork or piano—if available—can be used for a pitch standard. A reversal of connections to the concentrated coil located inside of the large tone coil will also reduce the range of the Theremin.

(6) REVERSED ACTION OF PITCH CONTROL

This condition is caused by the fixed pitch oscillator being at a lesser frequency than the variable pitch oscillator. Such action is caused by the fixed pitch oscillator trimming condenser having too much capacity, the variable pitch oscillator having too little capacity or both. The remedy is to decrease and increase the capacity of the respective trimming condensers until normal operation is secured.

(7) HIGH PITCHED NOTE

Should the Theremin give a high pitched squeal when no one is close to it the fixed pitch oscillator trimming condenser is adjusted to too great a capacity. Also too small an amount of capacity at the variable pitch oscillator, or both maladjustments, will cause the condition represented by the effects noted in Section 6—only to a lesser degree. Also this condition may be caused by the two pitch oscillators being too close to the frequency of the tone coil. This is caused by too much capacity at each of the two pitch oscillator trimming condensers. An open tone coil will cause a constant high frequency note with little variation caused by various positions of the hand in relation to the pitch control rod.

(8) SKIP EFFECT IN PITCH CONTROL

A pitch control abruptly changing from one frequency to another, instead of giving a smooth variation of tone indicates a poor Radiotron UY-227 in one of the pitch control oscillators. Usually in the three Radiotrons UY-227 used with each Theremin, there will be found two that will function satisfactorily in the pitch oscillator sockets. An erratic UY-227 in the oscillator socket will probably function normally as an audio amplifier. Too much capacity at each of the trimming condensers on the pitch oscillators may cause a skip effect in the range in addition to a greater than normal range. The effect noted in (?) may also be noted.

(9) SERVICE DATA CHART

Indication	Cause	Remedy
Radiotrons Fail to Light	No supply voltage	Test with A. C. voltmeter at loudspeaker auxiliary power receptacle (operating and safety switches should be closed)
	Defective safety switch	Test as above. Repair or replace
	Defective operating switch	Test as above. Replace
	Defective Power Transformer	Check by continuity tests (Section 13). Replace
	Defective Radiotrons	Replace
	UX-120 (only) fails to light	Low emission UX-280 or 171-A (No. 6) tube not oscillating. (A Neon glow lamp—such as the Cooper Hewitt type G10, 115-V—is a convenient test for oscillation. The brass base of the lamp should be held in the hand and the glass bulb near the pitch control rod or volume control loop). Circuits out of adjustment
Tubes light—Theremin fails to play	Defective wiring	Check by means of continuity tests, Sections 12—13
	Defective "Play-Off" switch	Replace
	Loudspeaker defective or disconnected	Connect O. K. speaker
	Tube Nos. 1, 3, or 6 not oscillating	Test tubes and continuity of circuits, Section 12
	Defective audio input transformer	Check with continuity test
	Grounds or opens	Check continuity Sections 12—13
Distorted Reproduction	Control grid connection open at UY-224	Attach contact cap
	Low emission or defective Radiotrons	Replace
	Poor wave form of A. C. supply current	Try resistances of from 500 ohms to 2000 ohms in series with control grid of UY-224
	Open 550-ohm resistor	Replace
	Defective audio transformer	Replace
	Open or imperfect chassis ground	Repair
Hum	Improper voltages at audio sockets	Check with tables Sections 10—11, Isolate trouble by continuity test Section 12
	Defective Loudspeaker	Replace
	Defective Radiotrons	Replace
	Open or shorted center tapped fixed condensers	Repair or replace
	Open by-pass or filter condensers	Test and replace
	Shorted filter reactor	Check by resistance measurement. Replace
	Open chassis grounds	Check from diagrams Figures 7—8
	Loose laminations in power transformer	Repair or replace

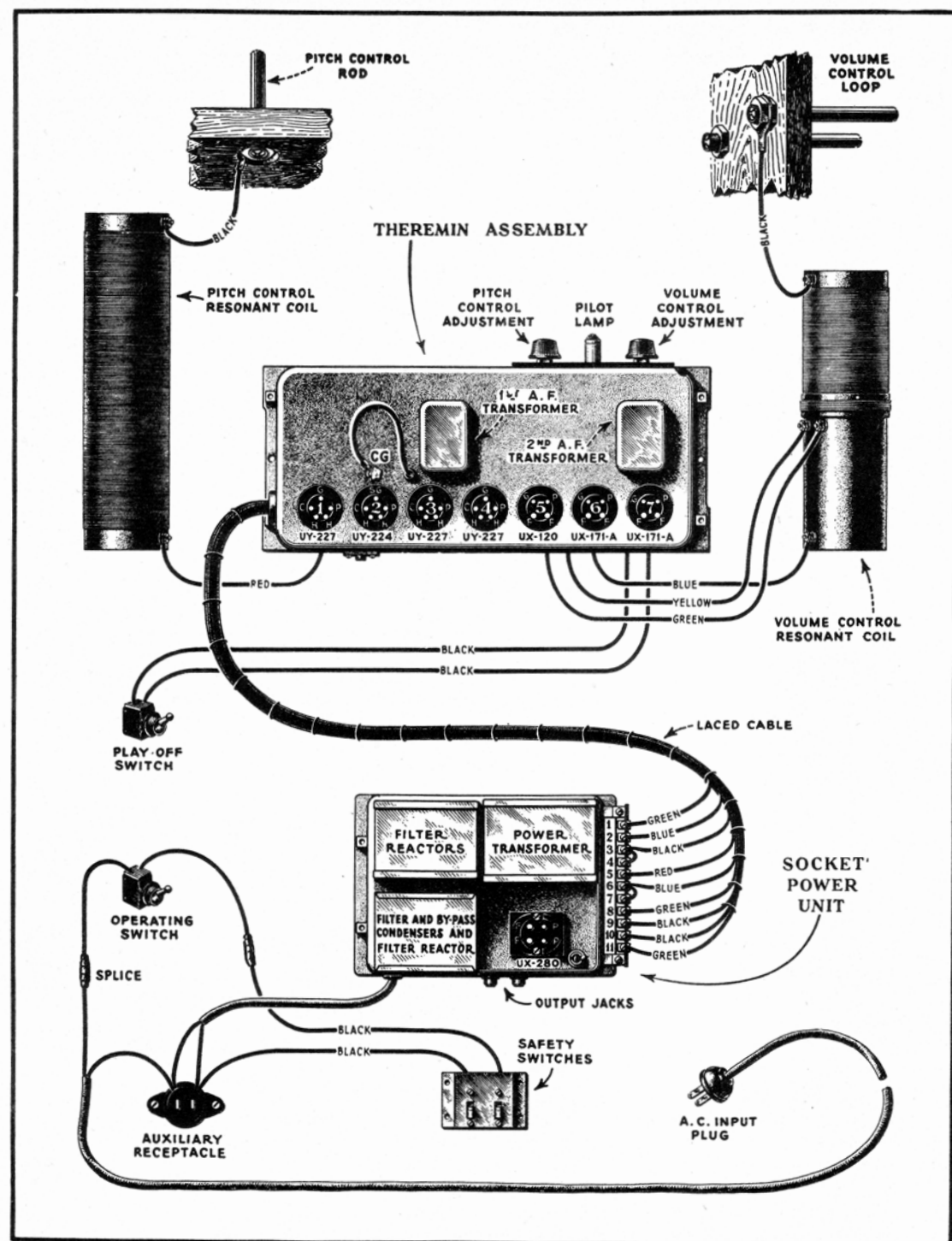

Figure 6—Complete layout and cable connections to the various assemblies

(10) S.P.U. TERMINAL STRIP VOLTAGES

Line 120 volts—Adjustment switch in 120-volt position

Use D.C. voltmeter with a 0-300 volt scale and at least 1,000 ohms per scale volt such as incorporated in Weston Model 537, Type 2, test set, for the D.C. voltage. The A.C. voltage may be measured with an A.C. voltmeter of suitable range. Refer to Figure 6.

Terminals Nos.	Cable on Tubes Lighted Volts	Cable Off Volts
1 to 6 (D.C.)	190	260
2 to 6*	190	260
3 to 6	140	230
5 to 6	29.0	0
8 to 9 (A.C.) rms	4.7	5.0
10 to 11 (A.C.) rms	2.5	2.8

* With Model 106 Loudspeaker connected to audio output pin jacks.

(These jacks may be shorted together for the purpose of taking a reading with negligible error in the result).

(11) THEREMIN RADIOTRON SOCKET VOLTAGES

Line 120 volts—Adjustment switch in 120-volt position

The following voltages taken at each Radiotron socket with the Theremin in operating condition should prove of value when checking with test sets such as the Weston Model 537, Type 2, or others giving similar readings. The plate currents shown are not necessarily accurate for each tube, as the cable in the test set will cause some circuits to oscillate, due to its added capacity. Small variations of voltages will be caused by different tubes and line voltages. Therefore the following values must be taken as approximately those that will be found under varying conditions. Refer to Figure 6.

Tube No.	Cathode to Grid Volts	Cathode to Screen Grid Volts	Cathode to Plate Volts	Plate Milamps	Filament or Heater Volts
1 UY-227	11.5	—	60.	7.1	1.95
2 UY-224	11.5	10.2	135.	0	1.95
3 UY-227	11.0	—	60.	5.5	1.95
4* UY-227	0	—	—2 to 40	Zero to 3.5	1.95
5* UX-120	0	—	110 to 64	0.5 to 4.1	unreadable
6* UX-171A	26 to 31	—	95.	12 to 17	4.6
7* UX171A	25 to 30	—	140 to 145	26 to 30	4.6

* The range of variation of the readings taken on Radiotrons Nos. 4, 5, 6 and 7 is caused by a change in the resonance point of the volume control loop circuit. Any object (such as the measuring instrument cable, body of the operator, etc.) coming in proximity to this circuit will give the variations noted above.

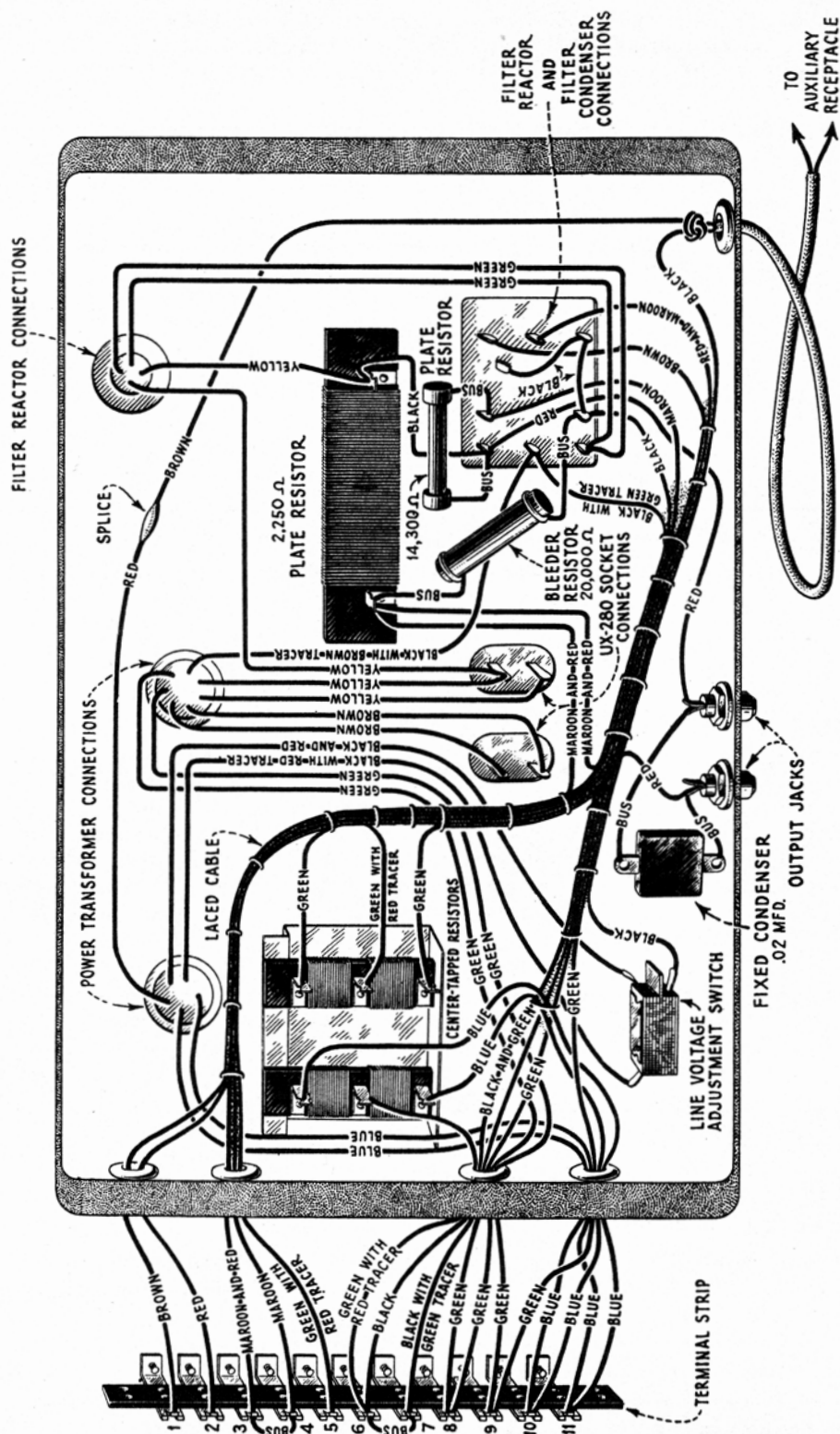

Figure 7—Wiring diagram of the socket power unit

Scanned and updated by Mike Buffington. RCATheremin.com

Scanned and updated by Mike Buffington. RCATheremin.com

(12) METHODS FOR CONTINUITY TESTS

In making a continuity test whether it be for the Theremin assembly or the S. P. U., the following procedure is recommended:

Disconnect the cable connecting the socket power unit to the Theremin assembly, the loudspeaker, and the A.C. supply cord at its outlet.

A pair of headphones with at least 4½ volts in series, or preferably a voltmeter with sufficient voltage to give a full scale deflection when connected across the battery terminals should be used in making these tests, for example, a 0-50 volt meter with a 45-volt "B" battery. The Radiotron socket contacts, numbers and lugs used in these tests are shown in Figure 6. The Theremin continuity wiring diagram is illustrated in Figure 8. The S. P. U. terminal numbers are shown in Figure 7.

Test leads should be of the flexible insulated type with partially insulated testing tips, so that false readings will not be obtained through contact with the hands. Similarly the hands should not touch the chassis or component parts.

The contacts of the test equipment should be placed across the terminals or leads indicated in the following test table under the column marked "Terminals." If the results are negative the cause of such negative effect will be found in the last column under the heading, "Incorrect Effect Caused By." The second column indicates the approximate correct resistance in ohms of most of the circuits tested.

(13) S.P.U. CONTINUITY TESTS

Remove UX-280 Radiotron and Disconnect Cable —Refer to Figure 8

Test Terminals	Correct Effect	Incorrect Effect	
		Indication	Caused by
Terminal No. 1 to filament of rectifier socket	1000 ohms	Open	Open reactor
No. 1 to No. 7	22,000 ohms	Shorted	Shorted filter condenser
No. 2 to one loudspeaker pin jack	Closed	Open	Open lead
No. 2 to other pin jack	Open	Closed	Shorted 0.02 condenser
No. 3 to No. 4	Shorted	Open	Open connection
No. 3 to No. 1	2500 ohms	14,000 ohms 2250 ohms	Open 2250-ohm resistor Open 14,300-ohm resistor
No. 3 to No. 6	20,000 ohms	Open Shorted	Open 20,000-ohm resistor Shorted 0.5 mfd. condenser
No. 5 to No. 8 or 9	13 ohms	25 to 30 ohms	Open power transformer winding
No. 6 to No. 10 or 11	13 ohms	25 to 30 ohms	Open power transformer winding
No. 7 to either plate contact of rectifier socket	190 ohms	Open	Open connection or open winding in power transformer
No. 8 to No. 9	Shorted	60 ohms	Open 5-volt filament winding
No. 10 to No. 11	Shorted	60 ohms	Open 2.5-volt filament winding
Across contacts of auxiliary power receptacle	3 to 6 ohms	Open	Open primary of power transformer or open 110-120-volt switch
Across blades of AC input plug with auxiliary receptacle shorted	Closed	Open	Open operating switch, open safety switch, open lead or connection
From either contact of auxiliary receptacle to frame	Open	Closed	Grounded primary in power transformer

(14) MAIN ASSEMBLY CONTINUITY TESTS

Remove Radiotrons and disconnect cable—Refer to Figure 8—A D.C. voltage is used in making the tests and the resistance values given are D.C.

Circuit	Test Terminals	Correct Effect	Incorrect Effect	
			Indication	Caused By
Grid	G1 to frame	5000 ohms	Open	Open No. 1 oscillator coil or 5000-ohm resistor or both
	Control grid No. 2 or G3 to frame	5000 ohms	3 ohms	Shorted 0.5 mfd. condenser
			Open	Open No. 2 oscillator coil or 5000-ohm resistor or both
	G4 to frame	5000 ohms	Shorted	Shorted 0.5 mfd. condenser
			Open	Open secondary audio transformer No. 1, or open ground connection
	G5 to filament 5	Shorted	Open	Open connection
			Shorted	Shorted 0.5 mfd. condenser or grounded lead
	G5 to frame	100000 ohms	Open	Open grid oscillator coil or 625-ohm resistor or 420-ohm resistor
			Shorted	Shorted fixed or trimmer condenser
	G6 to frame	1100 ohms	Open	Shorted fixed or trimmer condenser
G6 to P6	Open	Shorted	Shorted fixed or trimmer condenser	
		Shorted	Closed or defective "Play-Off" switch grounded or shorted secondary No. 2 audio transformer	
G7 to frame (Play-Off switch open)	5000 ohms	Open	Open audio transformer secondary	
		1/4 meg-ohm		
Plate	P1 to frame	Open	Shorted	Shorted 2 mfd. condenser
	P1 to P2	11000 ohms	Open	Open 10,000-ohm resistor or No. 1 audio transformer primary
			Shorted	Open plate coil of fixed or variable pitch oscillator
	P1 to P3	5 ohms	Open	Open plate coil variable pitch oscillator or open 10,000-ohm resistor
	P1 to Lug 1 (Green)	10000 ohms	Open	Open primary first audio transformer
	P2 to Lug 1 (Green)	1000 ohms	Open	Open primary second audio transformer or open 100,000-ohm or 420-ohm resistor
	P4 to frame	105,000 ohms	Open	Shorted 0.5 mfd. condenser
			1000 ohms	Open 1000-ohm resistor
	P5 to Lug 3 (Black)	1000 ohms	Open	Shorted 2 mfd. condenser
			Shorted	Open plate coil of volume control oscillator
P5 to frame	Open	Shorted	Shorted 2 mfd. condenser	
		Open	Shorted 1 mfd. condenser	
P6 to Lug 3 (Black)	1000 ohms	Open	Shorted 2 mfd. condenser	
		Shorted	Shorted 1 mfd. condenser	
P6 to frame	Open	Shorted	Shorted 2 mfd. condenser	
		1000 ohms	Shorted 1 mfd. condenser	
P7 to Lug 2 (Blue)	Shorted	Open	Open connection	
		Shorted	Grounded lead	
P7 to frame	Open	Open	Open connection or lead	
		Closed		
C1, C2, C3, or C4 to frame	Closed	Open	Open connection or lead	
		Open		
F5 to frame	100,000 ohms	Open	Open connection or 100,000-ohm resistor or 420-ohm resistor	
		Open		
F6 or F7 to frame	Open	Shorted	Grounded lead	
		Shorted	Grounded lead or connection	
Heater	H1, 2, 3, and 4 to frame	Open		
		Shorted		
Miscellaneous	Pitch control rod to G1	Open	550 ohms	Shorted pitch coil circuit fixed condenser
		Open	150 ohms	Shorted oscillator resonant coil fixed condenser

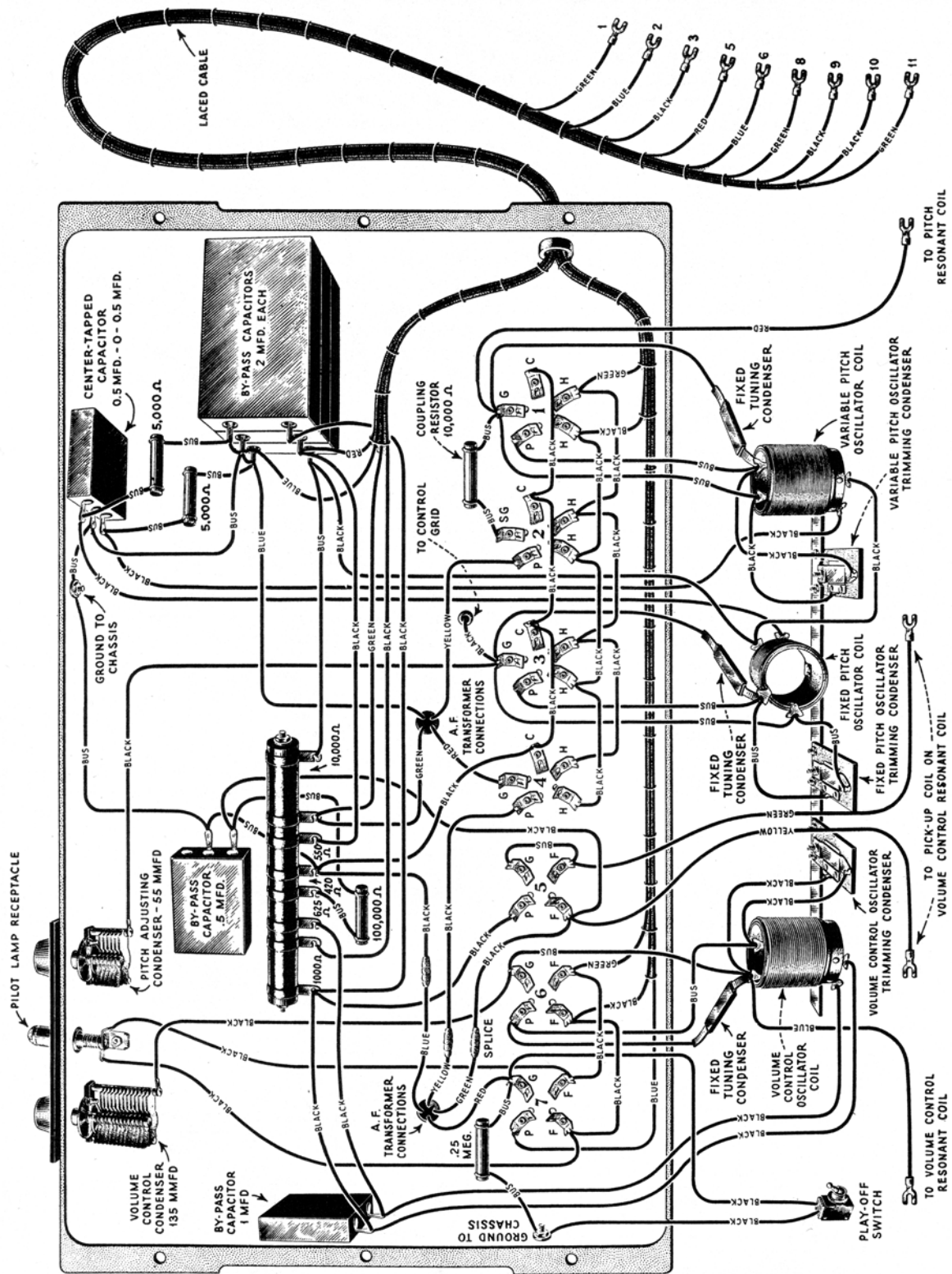

Figure 8—Wiring diagram and parts of the main assembly

Scanned and updated by Mike Buffington. RCATheremin.com

Scanned and updated by Mike Buffington. RCATheremin.com

PART II—MAKING REPLACEMENTS

The various assemblies of the RCA Theremin are readily accessible and replacements are easily made. However, there are some operations that require careful procedure as noted in the following paragraphs.

(1) REPLACING PARTS IN THE THEREMIN ASSEMBLY

All parts in the Theremin assembly are readily replaceable with tools ordinarily used in servicing radio receiving sets. However, the fixed condensers used across the variable, and pitch oscillator coils are somewhat more critical in values than other parts and may require some experimental work before a satisfactory replacement is made. These condensers are roughly adjusted to the pitch coil and after a replacement is made, the Theremin should be adjusted for correct operation by means of the trimming condensers. If this is not possible then a substitution for the condenser just replaced should be tried and one found that will allow a correct adjustment to be made by the trimming condensers. A condenser that does not function satisfactorily in one Theremin instrument may prove O.K. in another.

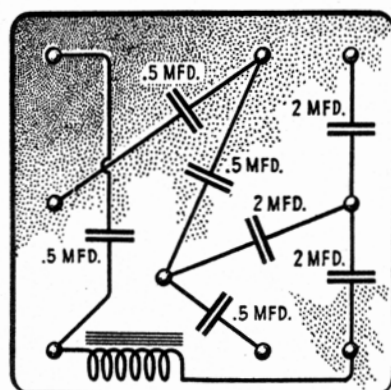

Figure 9—Internal connections of filter and by-pass condensers, and filter reactor

When replacing a pitch control coil, sometimes a similar condition will result. If after replacing a pitch coil it is found that the maximum range is not obtained by adjustment of the trimming condensers one of the following procedures must be used.

- (a) Try several pitch coils. One may be found of the correct inductance for use in place of the defective one.
- (b) If the range is low, that is less than 1100 cycles, try removing a few turns from the coil and readjusting the trimming condensers.
- (c) Replace both the fixed condensers across the fixed and variable pitch oscillators with ones of a greater capacity. Replacing one without the other will not remedy the situation. Both must be replaced simultaneously.

(2) REMOVAL OF PARTS AND LOCATION OF CABLE

The cable that is used to connect the Theremin chassis and the S. P. U. is clamped securely in a definite place on the inside of the cabinet. Whenever any assembly is removed, and this cable is shifted from its position, it is very important that it be returned to its original position when the Theremin is returned to normal operation. Failure to have this cable in its normal position may result in inability to adjust the Theremin for normal operation.

The errors found in Chart 10: S.P.U. Terminal Strip Voltages & tube numberings in Figure 4 have been fixed in this document. Scanned from the 1929–1930 RCA Victor Service Notes. Updated by Mike Buffington. RCATheremin.com

